

M-Series

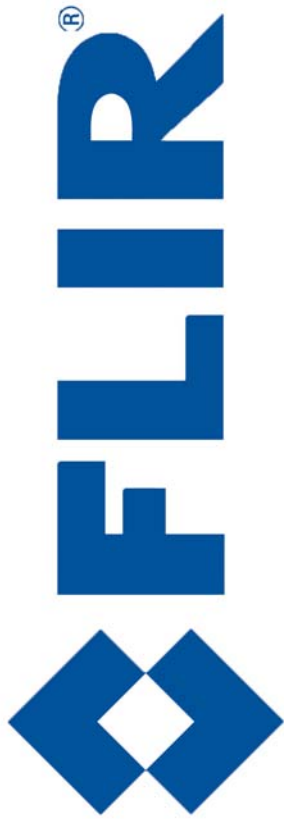

432-0003-00-12
Revision 150
Jul 2014

Installation Guide

© FLIR Systems, Inc., 2012. All rights reserved worldwide. No parts of this manual, in whole or in part, may be copied, photocopied, translated, or transmitted to any electronic medium or machine readable form without the prior written permission of FLIR Systems, Inc.

Names and marks appearing on the products herein are either registered trademarks or trademarks of FLIR Systems, Inc. and/or its subsidiaries. All other trademarks, trade names, or company names referenced herein are used for identification only and are the property of their respective owners.

This product is covered by one or more of US Patent Nos: 7470904; 7034301; 6812465; 7470902; 6929410 and other patents pending or design patents pending.

The M-Series thermal imaging system is controlled by US export laws. There are special versions of this system that are approved for international distribution and travel. Please contact FLIR Systems if you have any questions.

FLIR Systems, Inc.
70 Castilian Drive
Goleta, CA 93117
Phone: +1.888.747.FLIR (+1.888.747.3547)

www.flir.com/maritime

Document Number: 432-0003-00-12, Revision 150

Document History

Revision	Date	Comment
100	June 2009	Initial release
110	February 2010	Release of M-320L and M-324XP and minor changes
120	December 2010	Release of M-625XP, M-324L, and M-625L Replacement of M-320L and M-626L
130	January 2011	Minor corrections
140	Jan 2012	Release of M-618CS Minor corrections and style changes
150	Jul 2014	Added additional information for top-down riser, ball-down installations and preventative action to avoid corrosion problems,

Contents

CHAPTER 1 Installing M-Series Systems	3
Additional References	4
Documentation Conventions	4
Warnings and Cautions	5
Installation Overview	6
Installation Planning	7
General Location Considerations	7
Camera Location Considerations	7
Camera Mounting Options	8
Camera Video Options	9
Joystick Control Unit (JCU)	9
Multiple JCU/Camera Installations	10
Physical Installation	11
Installing the Camera Unit	11
Installing the Joystick Control Unit (JCU)	13
Electrical Connections	14
Proper Grounding	15
Connecting Power	15
Video Connections	16
Ethernet Connections	16
CHAPTER 2 M-Series Reference	17
Introduction	17
M-Series Maintenance	17
Cleaning the JCU	17
Cleaning the Camera Optics	17
Cleaning the Camera Body	18
Specifications	18
External Standards	19
Acronyms	20
Feature Comparison of M-Series Models	22

This page is intentionally blank.

Installing M-Series Systems

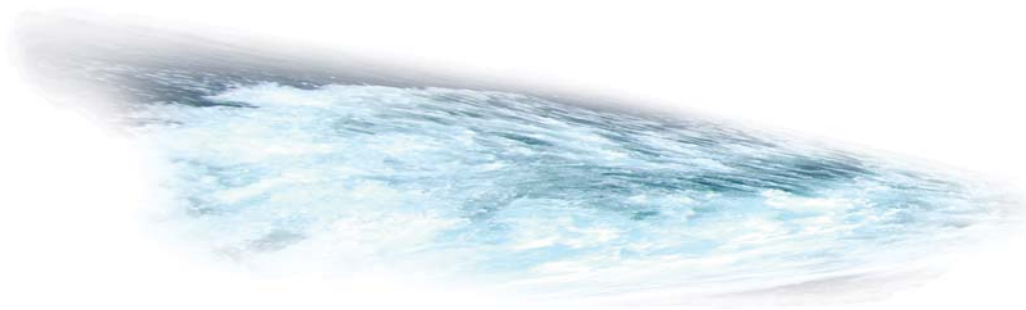

This manual describes the installation of the M-Series camera. If you need help or have additional questions, please call to speak with our support experts; see the phone numbers on the back cover of this manual.

M-Series is a maritime thermal imaging system for use on most types of vessels. The system is available in two configurations:

- The single payload models have a single thermal imaging camera.
- The dual payload models are equipped with both a thermal imaging camera and a visible-light (DLTV) camera, either low-light or color.

The infrared (IR) thermal camera provides night-time imagery, even in total darkness, based on temperature differences. The thermal camera provides a clear video image even under completely dark conditions because it is sensitive to thermal infrared energy. The infrared camera supports either 2X or both 2X and 4X zoom, depending on the model.



On dual payload models, the two integrated DLTV camera options provide either black and white imagery in low-light conditions or color imagery. The DLTV cameras provide enhanced navigational abilities in a variety of conditions, for example, during twilight hours or when operating along intercoastal waterways and near harbor entrances. The color camera dual payload model supports continuous zoom.

One M-Series model (indicated by an S suffix) includes a mechanical stabilization feature that improves image stability. The stabilization feature compensates for the motion of the vessel and improves the utility of the camera video output when operating in rough seas or swell conditions.

For a complete list of models and a comparison of key features, see “Feature Comparison of M-Series Models” on page 22.

This manual includes information about the following topics:

- Installation overview
- Mounting the camera and its components
- Connecting the electronics
- Maintaining the camera
- Parts list and other reference information



Additional References

Your M-Series camera comes with a complete documentation set on a CD (FLIR Doc. # 432-0003-00-16) that includes this manual as well as others. All documents are in PDF format and can be viewed with Adobe Acrobat Reader:

- *M-Series Operator's Manual* (FLIR Doc. # 432-0003-00-10) contains information about how to configure, use, and operate the camera.
- *M-Series Quick Start Guide* (FLIR Doc. # 432-0003-00-11) is a double-sided card that shows the functions executed by the various JCU buttons.
- *M-Series Interface Control Document (ICD)* (FLIR Doc. # 432-0003-00) is an extensive set of CAD drawings with detailed component dimensions, wiring schemes, mounting dimensions, and several possible system configurations using more than one JCU.

This manual frequently refers to the ICD drawings for details during the installation steps. You should ensure that you have these drawings available before beginning the install.

The ICD drawings are also available from the FLIR Web site:

<http://www.flir.com/cvs/americas/en/maritime/ae/>

You may also refer to the Resources Web page for up-to-date documentation:

<http://www.flir.com/cvs/americas/en/maritime/resources/>

Documentation Conventions

For safety, and to achieve the highest levels of performance from the M-Series system, always follow the warnings and cautions in this manual when handling and operating the M-Series camera system.



Warning: Warning notices are used to emphasize that hazardous voltages, currents, temperatures, or other conditions that could cause personal injury or death exist with this equipment, or may be associated with its use.



Caution: Caution notices are used where equipment might be damaged if care is not taken or an operation might have an unexpected outcome.



Note: Notes call attention to information that is especially significant to understanding and operating the equipment.

Warnings and Cautions



Warning: Do not use the M-Series imaging system as the primary navigation system. Use it in conjunction with other navigation aids and a primary manual navigation system.



Warning: Use of insufficient wire gauge can result in fire.



Caution: Do not open the M-Series camera unit for any reason. Disassembly of the camera (including removal of the cover) can cause permanent damage and will void the warranty.



Caution: Be careful not to leave fingerprints on the M-Series camera optics.



Caution: The M-Series requires a power supply of 12 – 24V DC nominal, 5 Amp maximum. Absolute voltage range: 10 – 32V DC. Operating the camera outside of the specified input voltage range or the specified operating temperature range can cause permanent damage.



Caution: During installation, ensure the cables exiting the bottom of the camera are not in contact with sharp edges, do not bend at sharp angles, and are not pinched between the bottom of the camera and the mounting surface. Do not pull on the cables with excessive force.



Caution: Follow industry standard best practices to avoid subjecting the camera to galvanic corrosion and electrolytic corrosion (electrolysis), especially with regards to the camera connections, camera base, its mounting surface and all fasteners.



Caution: Ensure the camera is installed in a location that will allow it to be accessed for regular periodic cleaning (fresh water rinse), inspection of mounting point integrity and mechanical soundness, and preventative maintenance.



Proper Disposal of Electrical and Electronic Equipment (EEE): The European Union (EU) has enacted Waste Electrical and Electronic Equipment Directive 2002/96/EC (WEEE), which aims to prevent EEE waste from arising, to encourage reuse, recycling, and recovery of EEE waste, and to promote environmental responsibility.

In accordance with these regulations, all EEE products labeled with the “crossed out wheeled bin” either on the product itself or in the product literature must not be disposed of in regular rubbish bins, mixed with regular household or other commercial waste, or by other regular municipal waste collection means. Instead, and in order to prevent possible harm to the environment or human health, all EEE products (including any cables that came with the product) should be responsibly discarded or recycled.

To identify a responsible disposal method where you live, please contact your local waste collection or recycling service, your original place of purchase or

product supplier, or the responsible government authority in your area. Business users should contact their supplier or refer to their purchase contract.

Installation Overview

The M-Series includes these standard components:

- Pan/tilt camera unit
- Joystick control unit (JCU) and JCU cover
- M-Series documentation package
- 7.7 meter (25-foot) double-shielded Ethernet cable
- Weathertight Ethernet coupler
- Mounting hardware and connectors



Joystick
Control Unit

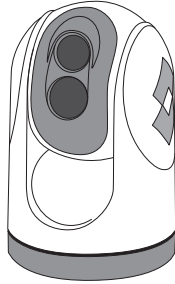

Dual Payload
Pan/Tilt Camera

You will need to supply the following items; required lengths vary depending on your boat's configuration. These items are available in standard lengths through FLIR.

- Electrical wire, for system power; up to 30.5 meters (100 feet), 3-conductor, gauge determined by cable length and supply voltage; see "Electrical Connections" on page 14 for details.
- Camera grounding strap.
- Up to 2 coaxial RG59/U video cables (with F-style connector at the camera end).
- Ethernet cables, if required, up to 100 meters (328 feet).
- Miscellaneous electrical hardware, connectors, and tools.

The mounting hardware included with the camera includes the following. For installations with special requirements, you may need to substitute other mounting hardware:

- Six M6 x 60 stainless steel-threaded studs with washers and nylock nuts or acorn nuts, for attaching the M-Series camera body. The length required depends on the mounting platform thickness. See "Camera Mounting Options" on page 8 for more details.
- Four captive screws for attaching the JCU.

Optional configurations have additional requirements:

- For a top-down installation, you may need an optional Top-Down Installation Kit. See "Camera Mounting Options" on page 8 for more information about the mounting kit.
- If you plan to install more than one JCU or additional cameras, additional network hardware (a PoE switch or a non-PoE switch with a PoE injector) is required. See "Multiple JCU/Camera Installations" on page 10 for more details.

Contact FLIR (phone numbers listed on the back cover of this manual) for more information regarding available accessories including JCUs, PoE equipment, video distribution amplifiers, cables, connectors, and mounting hardware.

Installation Planning

You should consider a number of factors in planning the installation of the M-Series camera and JCU.

General Location Considerations

First determine a good location for mounting the M-Series camera unit and the JCU. The camera requires at least three connections:

- One for power
- One network connection to the JCU or a PC
- One or two for the video display or displays

Optionally, more than one JCU can be used to control the camera and more than one display can be used to view the video. Also a single JCU can be used to control more than one camera. Most often, the JCU and the video monitor are mounted close together, as a pair, so the video can be viewed when the camera position (pan or tilt) is changed with the JCU.

When determining the component locations, consider how the system may be expanded in the future. For example, you may want to add an additional monitor, or perhaps a JCU and monitor pair.

Camera Location Considerations

Consider the following points when determining the camera location:

- Mount the IP66-rated M-Series camera body as high as practical, but without interfering with any radar, navigational, or communications electronics, and minimizing the degree to which vessel structures block the camera's 360° view. The camera's continuous-pan design lets it rotate and point in all directions. It is good practice to test the unit at the planned installation location with typical vessel electronics active prior to mounting the camera.
- Mount the camera as close to the vessel's center line as possible so you will have a symmetrical view of on-coming traffic, obstacles, and other navigational hazards.
- An appropriate camera mount suited for the camera mass and potential vibration and mechanical shock is important for proper camera functioning. The camera is tested to hold position for mechanical shock up to 9g transverse and 15g vertical. Improper mounts that are loose and/or resonate can magnify vessel impacts causing the camera to be unable to maintain pointing direction.
- A final location consideration is the camera's relation to other navigation devices. If you are relying on a magnetic compass for navigation and direction, you should establish a "compass safe distance" for any object placed in its vicinity, especially any electronic equipment. The magnetic compass safe distance for the camera is 20 cm (7.9 in).
- Ensure the camera is installed in a location that will allow it to be accessed for regular periodic cleaning (fresh water rinse), inspection of mounting point integrity and mechanical soundness, and preventative maintenance.

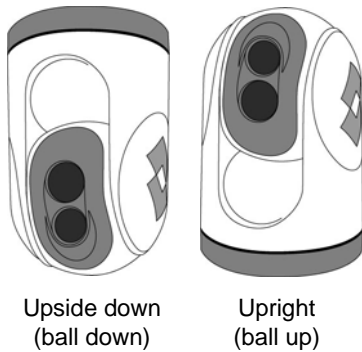
Upside down
(ball down)Upright
(ball up)

Camera Mounting Options

Your M-Series camera—except for the M-618CS model—can be installed in an upright or upside down position.

Warning: The M-618CS model, which is a mechanically stabilized system, must be installed in the ball-up orientation.

Upright Installation

In most installations, the M-Series is mounted upright on top of a mounting surface, with the pan/tilt base below the camera; this is known as the ball up orientation. Optionally, the unit (unless it is the M-618CS model) can be hung upside down or ball down. Unless otherwise noted, these mounting instructions assume an upright installation; refer to “Mounting Upside Down” on page 12 for information about ball down installations.



Warning: When mounting the camera in a ball-down position, the installer must ensure the camera is installed with adequate drainage so that standing water does not collect above the cable glands. Standing water will eventually seep past the cable gland seals and compromise the internal electronics. Failure to properly install or seal these glands could void the camera warranty.

Once the mounting location has been selected, verify that both sides of the mounting surface are accessible. With the supplied hardware, the camera can be mounted to a platform that is up to 41 mm (1.6”) thick. Depending on the thickness of the mounting platform, the installer can choose to provide other mounting hardware, rather than using the supplied threaded studs and nylock/acorn nuts. The camera mounting surface must be at least as large as the footprint of the camera itself to ensure an adequate seal with the O-ring.

You do not need to remove the screws in the base of the camera or disassemble the camera unit. The camera unit is sealed at the factory. Disassembling the camera will compromise the seals and will void the warranty.

Top-Down Installation Kit

Generally the M-Series camera is secured directly to a surface using threaded studs that extend from the base through the mounting platform and are secured from below. If it is not possible to access the space below the mounting platform, you can mount the camera from above the surface with the top-down mounting accessory kit. This type of installation makes use of a mounting riser, an optional accessory available from FLIR.

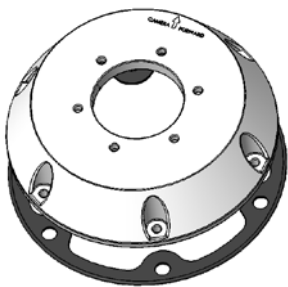

Top-down riser

To install, the camera is first mounted to the accessory riser, then the riser is secured to the surface with screws from above. The mounting riser allows space between the camera base and the mounting surface for the cable connections.

Camera Video Options

The M-Series gimbal assembly has either one or two video cables:

- The cable labeled IR is for the composite—also known as analog—video signal from the thermal (infrared) camera. This is the only cable on single payload cameras.
- On dual payload models, the cable labeled VIS/IR is for video from either the thermal camera or the DLTV camera. You use the JCU to determine which output displays.



Joystick Control Unit

The video from dual payload models can be output on one or two video displays. If only a single display with a single video input is available, connect the cable labeled VIS/IR to the display. If the display has more than one video input, both video cables can be connected to the same display. In this type of installation, switching between the thermal and visible video channels is performed with the display controls, rather than the JCU.

Joystick Control Unit (JCU)

Mount the JCU in a convenient area that is close to the monitor being used to display the M-Series video output. Make sure the area you choose leaves enough room for the cable under the JCU (refer to the M-Series ICD for dimensions). The magnetic compass safe distance for the JCU is 55 cm (21.7 in).

The JCU can be mounted to the dash (or other surface) in any orientation, using four captive mounting screws that hold panel mounting clamps. When the mounting screws are tightened, the panel mounting clamps rotate and extend away from the JCU at a right angle, and come into contact with the mounting surface. The JCU can be mounted to dash thicknesses ranging from 0.16 – 4.45 cm (0.063 – 1.750 in). A trim bezel snaps on top of the JCU to cover the mounting screws. See “Installing the Joystick Control Unit (JCU)” on page 13 for detailed instructions.

JCU Connection to Camera

The JCU is a Power over Ethernet (PoE) device and can be connected to the camera directly with the included 7.6 meter (25 feet) double-shielded Ethernet cable or a user-supplied cable of sufficient length. In this case, the JCU draws its power from the camera.

Alternatively, the camera and the JCU can be connected together via an Ethernet switch; this type of configuration allows more than one JCU or camera to be used. The JCU draws its power through the Ethernet connection, so a PoE injector or PoE switch is required.

Prior to Cutting/Drilling Holes

Determine if any interior trim panels must be removed in order to gain access to the mounting hardware, and remove them ahead of time.

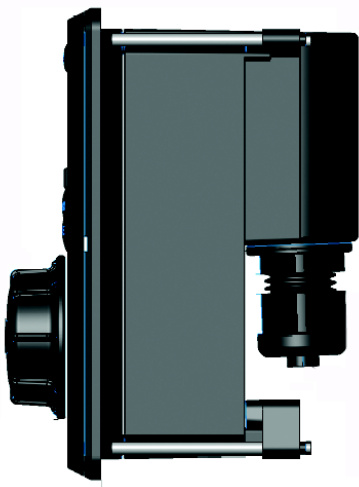

When selecting a mounting location for the M-Series, consider cable lengths and cable routing. Ensure the cables are long enough, given the proposed mounting locations and cable routing requirements, and route the cables before you install the components.

If you are using the top-down installation kit, the riser should be used as a template for the location of the drill holes and cable access hole.



Caution: When installing the camera, do not tighten the fastener in the threaded hole so far that it contacts the bottom of the threaded hole. Maximum insertion should not exceed 6 mm (0.23 in), and torque should not exceed 12 N·m (8.8 lbf·ft).

Use power cables that have sufficient dimensions to ensure safety and video and communication cables that have sufficient dimensions to ensure adequate signal strength.

To ensure a proper seal between the camera unit and the vessel, an O-ring should be installed in the camera base. The O-ring will seal properly with a surface that is flat to within 0.15 cm (0.06 in) over the diameter of the base of the camera. If it is necessary to install on a surface that does not meet that criteria, a marine-grade sealant (3M 4200 or equivalent) must be used rather than the O-ring.

To ensure a proper seal around the JCU, the supplied gasket must be applied to the JCU and the cutout opening for the JCU should precisely match the template. If the cutout opening is too large, the gasket around the JCU may not cover the opening adequately.

Multiple JCU/Camera Installations

In some installations, the system may include additional components, such as additional cameras or JCUs, video equipment, or network equipment. More than one JCU can be used to control the camera, and more than one display can be used to view the video. Also a single JCU can be used to control more than one camera and optionally you can also use a PC to control the camera.

Refer also to the M-Series ICD (FLIR Doc. # 432-0003-00) for interconnect diagrams showing several possible system configurations using more than one JCU.

The following diagram shows a possible system configuration using:

- A video amplifier (PN 4108996) supplied by FLIR that supports output to four video devices
- POE Injectors (PN 4113746) supplied by FLIR for DC/DC Power over Ethernet

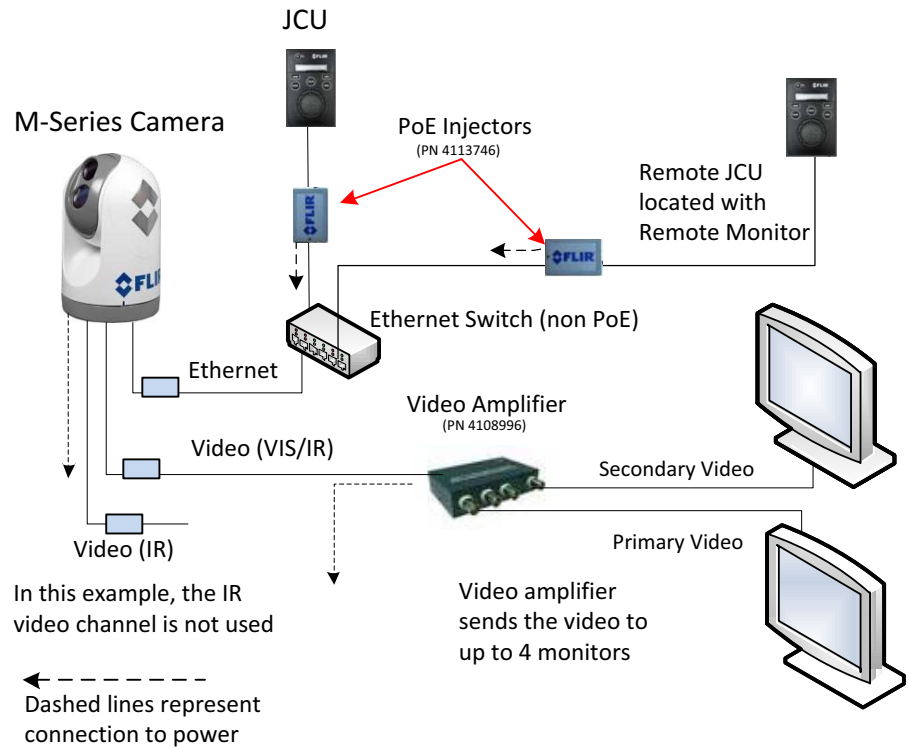

Physical Installation

Use a thread-locking compound such as Loctite 242 or equivalent with all metal-to-metal threaded connections.

Installing the Camera Unit

With the exception of the M-618CS model, which must be installed in the ball-up orientation, the M-Series camera can be mounted in an upright or upside down position. Two O-rings are provided for use during the camera installation. You should choose the one most appropriate for your configuration:

- Part # AS568A-427 is typically used for the upright installation. Its dimensions (in millimeters and inches):
120 mm ID x 7 mm (4.75 in ID x 0.25 in) DIA
- Part # A3568A-334 is used for certain ball-down installations. Its dimension (in millimeters and inches):
67 mm ID x 5 mm (2.63 in ID x 0.19 in) DIA

As an alternative to the mounting O-ring, you can use a marine-grade sealant such as 3M 5200 or the equivalent.

Mounting Upright

Caution: The cable connectors terminating the pigtail cables on the camera are not sealed connectors; therefore, appropriate sealing steps are needed to protect the connections and the camera.



Caution: Before drilling holes, ensure you have first followed the steps outlined in the planning section (page 7). For example, it is important to test the unit at the planned installation location with typical vessel electronics active prior to mounting the camera.



Using the template supplied with the camera as a guide, mark the location of the holes for mounting the camera. Make sure the template is oriented properly relative to the bow of the vessel; observe that the forward direction is reversed for the ball-down installation. If the template is printed, be sure it is printed to scale so the dimensions are correct. If you are using the top-down installation kit, the riser itself should be used as a template for the location of the drill holes and cable access hole.

Once the holes are drilled in the mounting surface, install the six (6) threaded studs into the base of the camera with thread-locking compound. Install the rubber O-ring in the base of the camera. Thread the power supply, video, and ethernet cables from the camera through the center hole, and then place the camera on the mounting surface so the threaded studs extend through the drilled holes. Then secure the camera body to the mounting surface with the supplied nuts and washers. As needed, the threaded studs can be replaced with studs of a different length or cut to a shorter length.

Mounting Upside Down

Do not allow water to collect above the cable glands



When the camera unit is mounted in an upside down orientation, with the ball down (select models only), the base must be rotated 180 degrees relative to the bow of the vessel, so the internal position sensors are oriented correctly. Refer to the arrow designations on the bottom of the camera base. A camera configuration setting accessible through the camera on-screen display (OSD) menu system is used to configure the camera for the ball-down position. See the *M-Series Operator's Manual* for details.

When mounting the camera in a ball-down position, the installer must ensure the camera is installed with adequate drainage so that standing water does not collect above the cable glands. Standing water will eventually seep past the cable gland seals and compromise the internal electronics.

If the base of the M-Series camera must be left exposed, the exit holes must be sealed with a Marine grade adhesive such as 3M 5200 or equivalent. Use a sufficient amount of sealant to prevent pooling of water above the glands.



Warning: Failure to properly install or seal these glands could void the camera warranty.

Installing the Joystick Control Unit (JCU)

The cable gland seal is designed for use with double-shielded category 5 Ethernet cable. To ensure a good seal and to maintain compliance with EMI ratings, a double-shielded cable is required.

The JCU enclosure is rated IP66 above the JCU mounting surface/gasket and rated IP64 behind or below the gasket.



Caution: An installation template is provided in the JCU ICD. If you print the template from the PDF file, ensure that it was printed to the correct scale by checking the dimensions prior to cutting any holes.

Standard JCU Mounting Instructions

1. Using the JCU template supplied as a guide in Doc. # 500-0385-19, mark the location of the rectangular opening that will allow the JCU to be recessed in the vessel's control console. Ensure the corners are marked precisely and cut square.
2. Apply the adhesive side of the rubber gasket to the back of the JCU on the surface that faces the mounting platform. The JCU comes with 4 panel mounting clamps that can be reversed when the thickness of the panel material is less than 0.79 cm (5/16 or 0.31 in); see instructions below. Ensure the mounting clamps are rotated inward and are recessed so the entire JCU fits into the hole.
3. Remove boots from both ends of the Ethernet cable, as it may interfere with the coupling gland. The boot may cause the RJ45 connector tab to depress, which can lead to intermittent connections.
4. Loosen or remove the cable gland nut on the JCU, and insert the Ethernet cable RJ45 connector through the gland nut. Once the Ethernet cable is connected to the JCU, replace the gland nut and turn the nut 1/4 turn beyond hand tight.
5. Insert the JCU into the hole and secure by turning the 4 corner screws clockwise. Rotate each screw one full turn and ensure the mounting clamps are rotated outward from the JCU housing. Tighten the screws to draw the mounting clamps up against the mounting surface and then tighten another quarter or half turn. Do not overtighten the screws.



Mounting the JCU to a Thin Panel

As shipped from the factory, the JCU can be mounted to dash thicknesses ranging from 0.79 – 4.45 cm (0.31 – 1.75 in). The clamps are set with the small foot on the clamp facing away from the panel and toward the front of the JCU, as shown below.



If you intend to mount the JCU to a panel of 0.79 cm (0.31 in) thickness or less, remove the clamps from the mounting screws, turn them around and thread them back onto each of the four screws. In this configuration, the clamp foot faces the rear of the mounting surface and allows the clamp to contact thinner panel surfaces while still allowing for proper compression of the JCU mounting gasket to form a watertight seal.



Electrical Connections



Watertight connectors/enclosures should be used on each of the electrical connections. Table 1.1 shows the connections for the cables attached to the camera.

TABLE 1.1 Connections Quick Reference

Cable Label	Wire	Comment
Power	Red	Nominal 12V DC / 24V DC Absolute range 10V to 32V DC 5 AMP maximum
	Black	DC return
	Green	Chassis ground
IR	F-Style Coax	Thermal camera video only
VIS/IR *	F-Style Coax	Use if only one display
JCU	RJ45	Use shielded Ethernet cable

*VIS/IR cable is only available on dual payload models.



Caution: During installation, ensure the cables exiting the bottom of the camera are not in contact with sharp edges, do not bend at sharp angles, and are not pinched between the bottom of the camera and the mounting surface. Do not pull on the cables with excessive force.



Caution: It is recommended that any built-up triboelectric charge on the Ethernet cable should be discharged *before* connecting it to the JCU and camera. This can be accomplished simply by pressing an ungloved finger across the Ethernet RJ45 connector of the cable for a few seconds.

Proper Grounding



Caution: Ensure the camera is properly grounded. Following best grounding practices, the camera chassis ground should use the lowest resistance path possible.

The green wire in the camera cable can be used to provide chassis ground for cable lengths under 2 m (6 ft). For longer cabling, the camera must be connected to a vessel ground using a low-resistance grounding strap connected directly to one of the M6 mounting bolts on the camera base as shown in the M-Series ICD (432-0003-00).

Failure to provide this connection may result in electrical interference between camera and other shipboard electronic systems. Furthermore, it is recommended that a bonded grounding scheme is used with a common ground between the chassis ground and electrical return, with the connection made as close as possible to the negative terminal of the battery.

Connecting Power

The camera itself does not have an on/off switch. Generally the M-Series camera will be connected to a circuit breaker and the circuit breaker will be used to apply or remove power to the camera. When power is supplied, the camera will be in one of three modes: Booting Up, Standby, or Powered On. The *M-Series Operator's Manual* has detailed information about powering and operating the camera.

Consider installing a fuse in line with the power connection to protect the camera from power surge or short circuit. Table 1.2 applies to both 12V and 24V operation.

TABLE 1.2 Fuse Recommendations

Model	Fuse
M-324L, M-625L, M-612L, M-618CS	5 amp
M-324XP, M-625XP	3 amp

The installer must use power cable wires that are sufficient size gauge or diameter for the supply voltage and total load (camera and length of cable run), to ensure proper supply voltage at the camera and adequate current carrying capacity. Table 1.3 lists recommended wire size for various cable lengths.

TABLE 1.3 Power Cable Wire Gauge Recommendation

Length in Meters (Feet)	Wire Gauge (AWG) for 12V Supply	Wire Gauge (AWG) for 24V Supply
8 (25)	16	18
16 (50)	14	18
24 (75)	12	16
32 (100)	10	16



Warning: Use of insufficient wire gauge can result in fire. Suggested gauge depends on supply voltage shown. For lower supply voltages, lower gauge wire must be used.

Video Connections

The video cables from the camera are terminated with F-type male connectors. Video cables of various lengths with F-type female connectors at one end and BNC-connectors at the other end are available from FLIR. The video cable used should be rated as RG59/U or better to ensure an adequate quality video signal.

Another alternative is to interconnect the camera video cable to a longer video cable using an optional F-type female-to-female adaptor (FLIR PN 4115330). For cable runs in excess of 100', a video amplifier should be used.

Ethernet Connections

The Ethernet cable from the camera can be connected to another Ethernet cable with the included RJ45 waterproof enclosure connector (FLIR PN 4115028).

The Ethernet network cable should be rated for use with PoE devices (IEEE802.3af) and should be 8-conductor T568B, Ethernet, double-shielded for EMI considerations (FLIR PN 308-0163-25 or equivalent).





Introduction

This chapter includes the following reference information:

- A summary of maintenance procedures
- A table of camera specifications
- Information about standards referenced during the installation procedure
- A glossary of acronyms
- A table comparing features of various M-Series models

M-Series Maintenance

The M-Series components are designed for years of rugged, trouble-free use. When the system is not in use, keep the JCU cover in place for additional protection.

Cleaning the JCU

To clean the JCU, use a soft cloth and clean water. Mild household cleaner such as Windex can also be used to remove tougher stains or spots. Do not use alcohol based cleaners or any type of solvents as this may discolor or damage the unit.

Cleaning the Camera Optics

Great care should be used with your camera's optics. They are delicate and can be damaged by improper cleaning. The M-Series thermal camera lenses are



designed for the harsh outdoor environment and have a coating for durability and anti-reflection, but may require cleaning occasionally. FLIR Systems Inc. suggests that you clean the lens when image quality degradation is noticed or excessive contaminant build-up is seen on the lens.

Rinse the camera housing and optics with low pressure fresh water to remove any salt deposits and to keep it clean. If the front window of the camera gets water spots, wipe it with a clean soft cotton cloth dampened with fresh water. If the window requires further cleaning, use a soft moist cotton-based cloth with isopropyl alcohol or dish soap.

Do not use abrasive materials, such as paper or scrub brushes as this will possibly damage the lens by scratching it. Only wipe the lens clean when you can visually see contamination on the surface. Never use ammonia-based cleaning products on the optics.

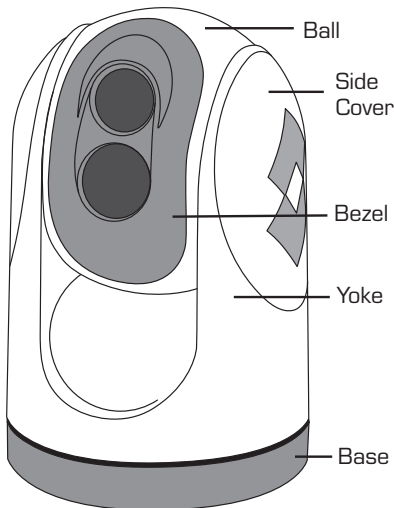

Camera Body Cleaning and Inspection

Do not pressure wash the camera, especially around the FLIR logos, as that could force water through the camera seals. Clean the interface between the yoke and base often to prevent accumulation of debris or salt deposits.

Routinely inspect the camera and its mounting surface to ensure it is installed securely, the coated surfaces are intact, and there are no signs of corrosion. When the camera is powered off, grasp it firmly at the base and confirm it is rigid and secure. Then hold the camera above the base and confirm it will rotate freely and without noticeable wobble or looseness around pan bearing.



Caution: If a camera becomes loose from its mounting point unexpectedly, it could potentially cause great bodily harm or even death. Ensure the camera is accessible for regular cleaning and inspection. Routinely inspect for mounting point integrity, mechanical soundness, and any signs of corrosion or unusual wear.



Caution: The M-Series is sealed at the factory against liquid water, suspended particulates, and other contaminants. It is important that you not open the camera for any reason, as it will compromise this seal and possibly damage the unit. Opening the M-Series camera will void the manufacturer's warranty.

If you have a problem with your thermal camera, do not attempt to repair it yourself. The M-Series camera is a sealed unit and can not be opened or serviced in the field. Consult your installation dealer or FLIR Systems Inc. for repair information.

Specifications

Table 2.1 lists details about physical characteristics, power usage, and environmental features of your M-Series camera.

TABLE 2.1 Specifications

Physical Characteristics	
Camera Size	17.8 cm (7 in) diameter by under 29.2 cm (11.5 in) tall
Camera Weight	Under 5.4 kg (12 lb), depending on the camera model
Joystick Size	9.1 X 14.2 X 8.13 cm (3.6 X 5.6 X 3.2 in) 3.17 cm (1.25 in) above platform including joystick
Joystick Weight	.45 kg (1 lb)
Power	
Camera Input Power	12 – 24 V DC nominal, 5 A Max Absolute range 10 – 32V DC (–10%/+30% per IEC 60945)
Camera Output Power (to JCU)	Power Over Ethernet (PoE) per IEEE 802.3af 48V mode B PoE, RJ45
JCU Input Power	Power over Ethernet (PoE) per IEEE 802.3af
Consumption	25W Nominal 42W Max (dual payload)
Environmental	
Operating temperature range	–25° C to +55° C (–11° F to +131° F)
Storage temperature range	–40° C to +85° C (–38° F to +185° F)
Automatic Window defrost	Standard (automatic at unit power-up)
Sand/dust	Mil-Std-810E
Automatic Window de-icing	Standard (automatic at unit power-up)
Water Ingress	IPX 6
Shock	15 g vertical, 9 g horizontal
Vibration	IEC 60945; MIL-STD-810E
Lightening Protection	Standard
Salt Mist	IEC 60945
Wind	100 knot (115.2 mph)
EMI	IEC 60945

External Standards

Table 2.2 lists other sources of information and standards definitions that may be useful during the installation of your M-Series camera.

TABLE 2.2 External References

Standard	Description
ANSI/SCTE 01 2006 "F" Port, Female, Outdoor	http://www.scte.org
IEC 60169-24	Radio-frequency coaxial connectors with screw coupling, typically for use in 75 Ohm cable distribution systems (Type F)
IEC 60945	Maritime navigation and radio communication equipment and systems general requirements
IEC 60529	Degrees of Protection Provided by Enclosures (IPX6)
IEC 60068	Basic Environmental Testing Procedures, Part 2: Tests
89/336/EEC	Electromagnetic Compatibility (EMC) directive
Directive 2002/95/EC	Restriction of the use of certain hazardous substances in electrical and electronic equipment (European Union)
Directive 2002/96/EC	Waste Electrical and Electronic Equipment Reg. 2006
TIA/EIA T568B	CAT5/RJ-45 wiring standard
IEEE 802.3 / IEEE 802.3u	10Base-T/100Base-TX Ethernet
IEEE 802.3af	Power over Ethernet (PoE) standard (48V/400mA/15.4W)
ANSI/SMPTE 170M - 1994	Composite Analog Video Signal (Supersedes RS-170A)
Directive 96/98/EC	Marine Electronics Directive (MED)

Acronyms

The following table lists each acronym that is used in this manual and its meaning.

Acronym/Term	Definition
AGC	Automatic Gain Control
ANSI	American National Standards Institute
API	Application Programming Interface
DLTV	Daylight TV, used to reference visible-band cameras
EAR	Export Administration Regulations

Acronym/Term	Definition
EMI	Electromagnetic Interference
FFC	Flat Field Correction
FLIR	Forward Looking Infrared
FoV	Field of View
FPS	Frames per Second (refresh rate)
HFoV	Horizontal Field of View
ICD	Interface Control Document
IEC	International Electrotechnical Commission
IEEE	Institute of Electrical and Electronics Engineers
IP	Internet Protocol
IR	Infrared or thermal
JCU	Joystick Control Unit
LCD	Liquid Crystal Display
LWIR	Long-wave infrared
MFD	Multifunction display
NMEA	National Marine Electronics Association
NTSC	National Television System Committee
PAL	Phase Alternating Line
P/T	Pan/Tilt
PoE	Power over Ethernet
SCTE	Society of Cable Telecommunications Engineers
SDK	Software Developer's Kit
UPnP	Universal Plug and Play
VDC	Volts, Direct Current
VIS	Visible (visible-band camera reference)

Feature Comparison of M-Series Models

The following table lists each M-Series model and its supported features. Each model is available in four variations, identified by a unique part number:

- <9 hz thermal frame refresh rate (FPS), NTSC video format
- 30 hz thermal frame refresh rate (FPS), NTSC video format
- <9 hz thermal frame refresh rate (FPS), PAL video format
- 25 hz thermal frame refresh rate (FPS), PAL video format

Note: Different frame formats and rates are used in the US (NTSC, 320 x 240 @ 30 FPS) and other parts of the world, such as Europe and China (PAL, 320 x 256 @ 25 FPS).

Model	Part Numbers	Camera Payload	Video Format	Thermal Video	Low-Light Video (DLTV)	Color Video (DLTV)	Thermal Video Resolution	Thermal Frame Refresh Rate	Mech Image Stabilization	HFOV	IR Digital Zoom
M-324XP	432-0003-05-00S	Single	NTSC	Yes	No	No	320 x 240	<9 Hz	No	24°	2x
	432-0003-05-00	Single	NTSC	Yes	No	No	320 x 240	30 Hz	No	24°	2x
	432-0003-06-00S	Single	PAL	Yes	No	No	320 x 256	<9 Hz	No	24°	2x
	432-0003-06-00	Single	PAL	Yes	No	No	320 x 256	25 Hz	No	24°	2x
M-625XP	432-0003-09-00S	Single	NTSC	Yes	No	No	640 x 480	<9 Hz	No	25°	2x and 4x
	432-0003-09-00	Single	NTSC	Yes	No	No	640 x 480	30 Hz	No	25°	2x and 4x
	432-0003-10-00S	Single	PAL	Yes	No	No	640 x 512	<9 Hz	No	25°	2x and 4x
	432-0003-10-00	Single	PAL	Yes	No	No	640 x 512	25 Hz	No	25°	2x and 4x
M-324L	432-0003-11-00S	Dual	NTSC	Yes	Yes	No	320 x 240	<9 Hz	No	24°	2x
	432-0003-11-00	Dual	NTSC	Yes	Yes	No	320 x 240	30 Hz	No	24°	2x
	432-0003-12-00S	Dual	PAL	Yes	Yes	No	320 x 256	<9 Hz	No	24°	2x
	432-0003-12-00	Dual	PAL	Yes	Yes	No	320 x 256	25 Hz	No	24°	2x
M-625L	432-0003-13-00S	Dual	NTSC	Yes	Yes	No	640 x 480	<9 Hz	No	25°	2x and 4x
	432-0003-13-00	Dual	NTSC	Yes	Yes	No	640 x 480	30 Hz	No	25°	2x and 4x
	432-0003-14-00S	Dual	PAL	Yes	Yes	No	640 x 512	<9 Hz	No	25°	2x and 4x
	432-0003-14-00	Dual	PAL	Yes	Yes	No	640 x 512	25 Hz	No	25°	2x and 4x
M-612L	432-0003-23-00S	Dual	NTSC	Yes	Yes	No	640 x 480	<9 Hz	No	12°	2x and 4x
	432-0003-23-00	Dual	NTSC	Yes	Yes	No	640 x 480	30 Hz	No	12°	2x and 4x
	432-0003-24-00S	Dual	PAL	Yes	Yes	No	640 x 512	<9 Hz	No	12°	2x and 4x
	432-0003-24-00	Dual	PAL	Yes	Yes	No	640 x 512	25 Hz	No	12°	2x and 4x
M-618CS	432-0003-31-00S	Dual	NTSC	Yes	No	Yes	640 x 480	<9 Hz	Yes	18°	2x and 4x
	432-0003-31-00	Dual	NTSC	Yes	No	Yes	640 x 480	30 Hz	Yes	18°	2x and 4x
	432-0003-32-00S	Dual	PAL	Yes	No	Yes	640 x 512	<9 Hz	Yes	18°	2x and 4x
	432-0003-32-00	Dual	PAL	Yes	No	Yes	640 x 512	25 Hz	Yes	18°	2x and 4x

This page is intentionally blank.



FLIR Systems, Inc.

CS World Headquarters

FLIR Systems, Inc.
70 Castilian Dr.
Goleta, CA 93117
USA
PH: + 1 805 964 9797
PH: + 1 877 773 3547 (Sales)
PH: + 1 888 747 3547 (Apps)
FX: + 1 805 685 2711
sales@flir.com

EUROPE

CS Eurasian Headquarters
FLIR Systems CVS BV
Charles Petitweg 21
4847 NW Teteringen - Breda
Netherlands
PH: + 31 (0) 765 79 41 94
FX: + 31 (0) 765 79 41 99
flir@flir.com

FLIR Systems, Inc.

Corporate Headquarters
FLIR Systems, Inc.
27700A SW Parkway Ave.
Wilsonville, OR 97070
USA
PH: + 1 503 498 3547
PH: + 1 877 773 3547
FX: + 1 503 498 3153
sales@flir.com