

**Infrared camera with
BI-SPECTRAL Technology**

Features:

- Time-synchronized visual image recording at up to 32 Hz (640 x 480 pixels)
- Real image camera is highly sensitive in low-light conditions
- Thermal images up to 128 Hz (160 x 120 pixels)
- Compact design 45 x 45 x 62 mm (1.77 x 1.77 x 2.44 in)

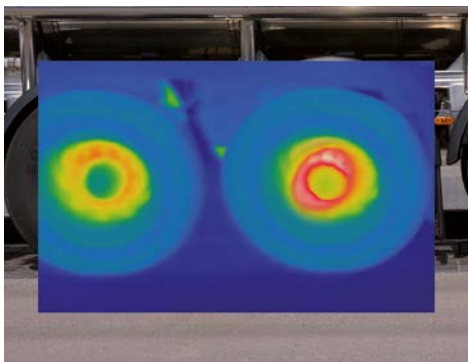
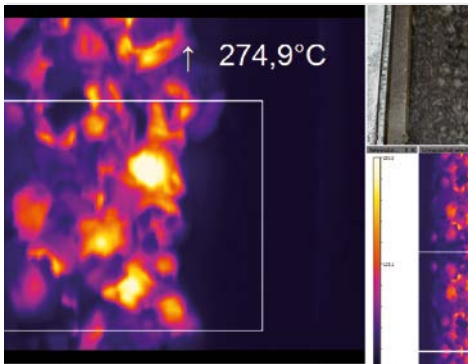
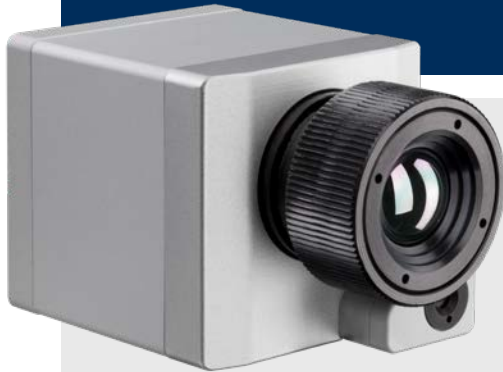

For further information as well as the product configurator, please visit:
www.optris.com/thermal-imager-pi200

Technical specifications

Optical resolution	160 x 120 Pixel
Detector	FPA, uncooled (25 µm x 25 µm)
Spectral range	7.5 – 13 µm
Temperature ranges	—20 ... 100 °C, 0 ... 250 °C, 150 ... 900 °C ¹⁾ , (-4 ... 212 °F, 32 ... 482 °F, [68] 302 ... 1652 °F) ¹⁾ optional temperature range: 200 ... 1500 °C ²⁾ (392 ... 2732 °F) ²⁾
Frame rate	128 Hz ³⁾
Optics (FOV)	6° x 5° FOV / f = 35.5 mm (1.40 in) or 23° x 17° FOV / f = 10 mm (0.39 in) (recommended for PI 230) or 41° x 31° FOV / f = 5.7 mm (0.22 in) (recommended for PI 200) or 72° x 52° FOV / f = 3.3 (0.13 in) mm
Thermal sensitivity (NETD)	0.08 K with 23° x 17° FOV / F = 0.8 0.3 K with 6° x 5° FOV / F = 1.6 0.1 K with 41° x 31° FOV and 72° x 52° FOV / F = 1
Visual camera	Optical resolution 640 x 480 pixels / frame rate 32 Hz ³⁾ Optics (FOV): 54° x 40° (PI 200), 30° x 23° (PI 230)
Accuracy	±2 °C or ±2 % (±3.6 °F or ±2 %), whichever is greater
PC interface	USB 2.0 / optional USB to GigE (PoE) interface
Process interface (PIF), standard	0–10 V input, digital input (max. 24 V), 0–10 V output
Process interface (PIF), industrial	2x 0–10 V input, digital input (max. 24 V), 3x 0–10 V output, 3x relay (0–30 V/ 400 mA), fail-safe relay
Cable length (USB)	1 m (3.3 ft) (standard), 5 m (16.4 ft), 10 m (32.8 ft), 20 m (65.6 ft) 5 m (16.4 ft) and 10 m (32.8 ft) also as HT cable (180 or 250 °C [356 or 482 °F])
Ambient temperature	0 °C ... 50 °C (32 °F ... 122 °F)
Storage temperature	–40 ... 70 °C (–40 ... 158 °F)
Relative humidity	20–80 %, non-condensing
Enclosure (size / rating)	45 x 45 x 62 mm (1.77 x 1.77 x 2.44 in) / IP 67 (NEMA 4)
Weight	215 g (7.58 oz), lens included
Shock / Vibration ⁴⁾	IEC 60068-2
Tripod mount	¼-20 UNC
Power supply	via USB
Scope of supply	• USB camera with 1 lens • USB cable (1 m [3.3 ft]) • Table tripod • Standard PIF with cable (1 m [3.3 ft]) and terminal block • Software package optris® PIX Connect • Aluminium case

¹⁾ Accuracy effective starting at 150 °C (302 °F) ²⁾ Not available für 72° lense
³⁾ Options: 1) IR with 96 Hz at 160 x 120 px; VIS with 32 Hz at 640 x 480 px
2) IR with 128 Hz at 160 x 120 px; VIS with 32 Hz at 596 x 447 px
⁴⁾ For further details see operator's manual

optris® PI 200 / 230

Dimensions

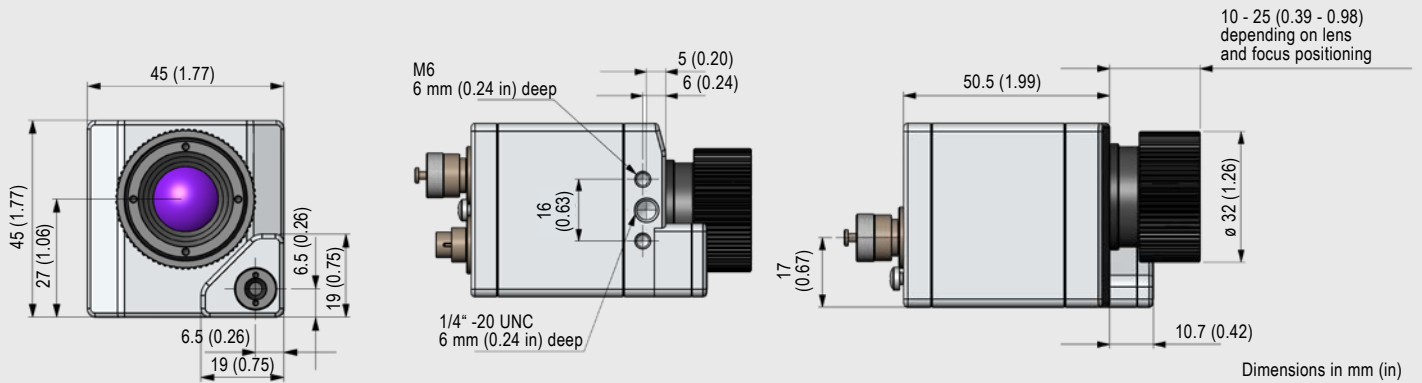

Process integration

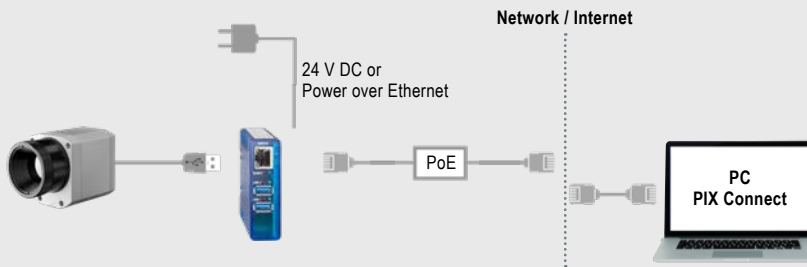

optris® USB-Server Gigabit 2.0

- Network connection via Gigabit Ethernet
- Full TCP/IP support incl. routing and DNS
- Two independent USB ports
- Power via PoE or external voltage supply at 24 – 48 V DC
- Galvanic isolation 500 V_{RMS}
- Remotely configurable via web based management

For further information please visit

www.optris.com/usb-server-industry-isochron

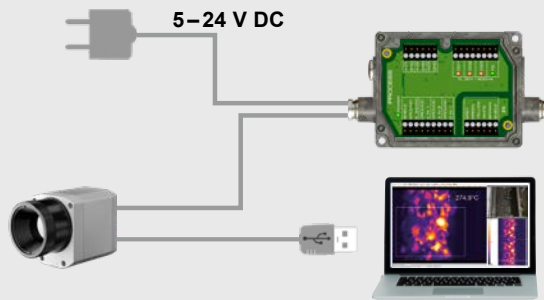

optris® Industrial process interface

- Use of camera for process monitoring in industrial environments
- Continuous fail safe monitoring of imager, software and cable connections
- 3 analog/ alarm outputs, 2 analog inputs, 1 digital input, 3 alarm relays, 1 fail safe relay

For further information please visit

www.optris.com/industrial-process-interface

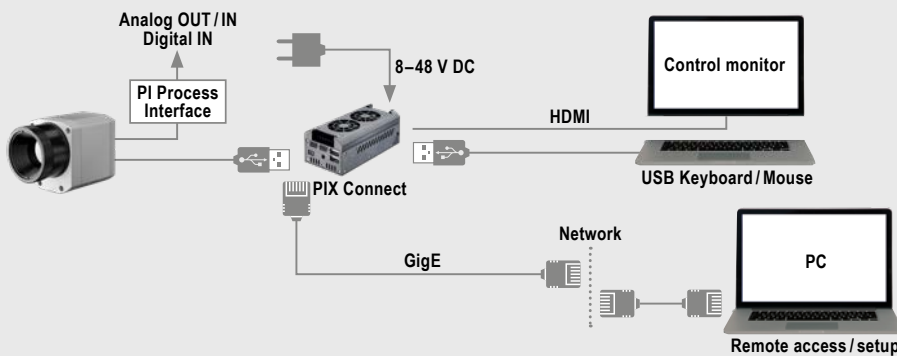

optris® PI NetBox

- Miniature PC as add-on to the PI series for stand-alone system
- Integrated hardware and software watchdog
- Connections: 2x USB 2.0, 1x USB 3.0, 1x Mini-USB 2.0, Micro-HDMI, Ethernet (Gigabit Ethernet), micro SDHC / SDXC card

For further information please visit

www.optris.com/pi-netbox